

INSTRUCTIONS

WESTERN FLUSH KIT ASSEMBLY

INTRODUCTION

Satellite portable restrooms and accessory kits must be assembled according to approved Satellite assembly procedures. Avoid variations in assembly procedures could adversely affect product life and warranty.

HARDWARE

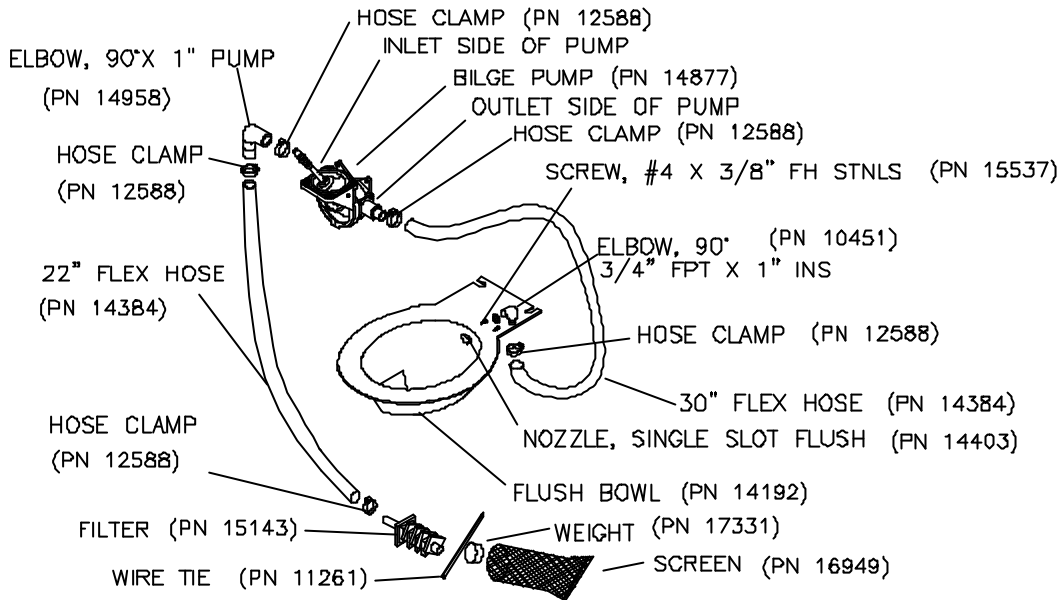

TOOLS

- Drill Elec/Cordless
- 5/16" Drill Bit
- 3 1/2" Hole Saw or Jig Saw
- Flat Blade Screwdriver
- Utility Knife
- Pencil

1. **Prepare Hover, Freedom2, or Liberty tank for the flush bowl assembly.** Measure to center as shown and place top plate of pump approximately as shown below. Mark and drill the four mounting holes using 5/16" drill bit and the center hole using 3 1/2" hole saw.

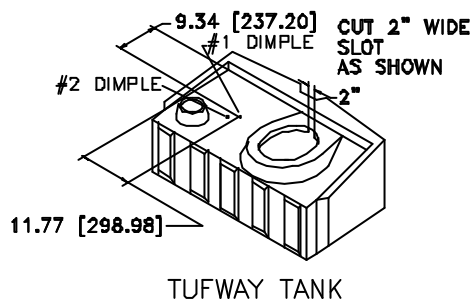
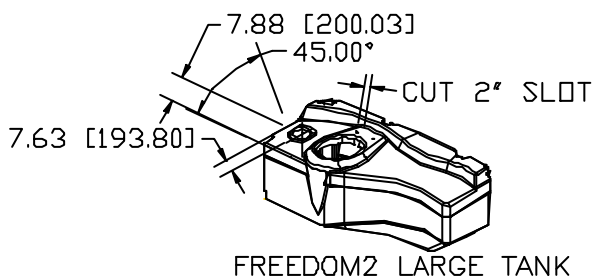
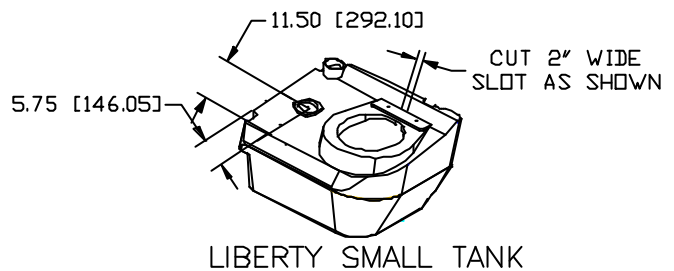
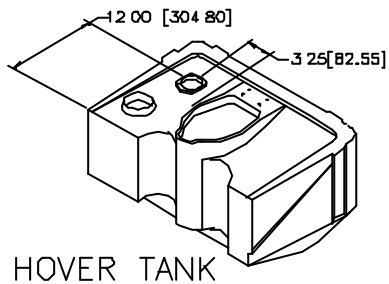

2. **Prepare Tufway tank for the flush bowl assembly** as shown above. Drill measured hole #1 with 3 ½" hole saw, drill #2 hole with 5/16" drill bit. Place top plate of pump as a temp plate over holes; align large holes and 5/16" holes. Drill the three remaining mounting holes using 5/16" drill bit.
3. **Install pump and hose assembly.** Install pump assembly from inside the tank. Make sure the rubber boot extends through the hole and is seated on top of the tank. (Figure 1).
Attach flush bowl assembly to tank. Tighten the screws that attach the toilet seat to the tank. (Figure 2).
Attach pump outlet hose to the bowl assembly. Tip bowl up to attach the hose and hose clamp. (Figure 3).

FIGURE 1

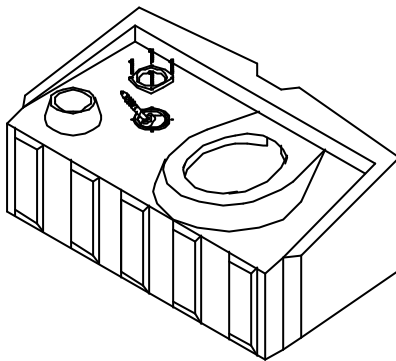

FIGURE 2

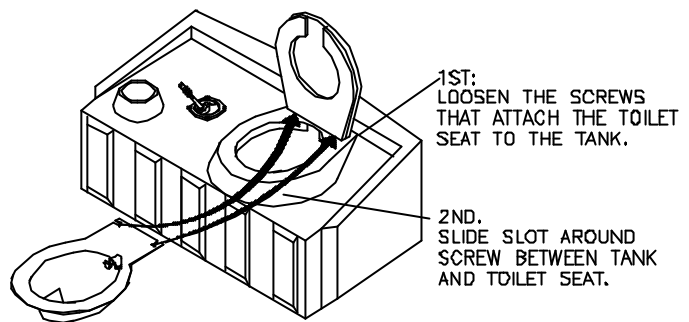
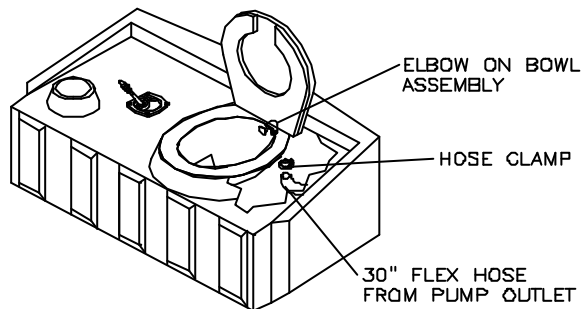

FIGURE 3



Satellite Industries Europe: 67 avenue de la Toison d'Or - 1060 Bruxelles - Belgium
tel : 0032 / 2-542 56 56 fax : 0032 / 2-542 56 57
moreinfo@satellite.be - www.satellite.be