

# INSTRUCTIONS HIGH RISE HANGER

## INTRODUCTION

Satellite portable restrooms and accessories must be assembled according to approved assembly procedures. Variations in assembly could adversely affect product life and warranty.

## HARDWARE

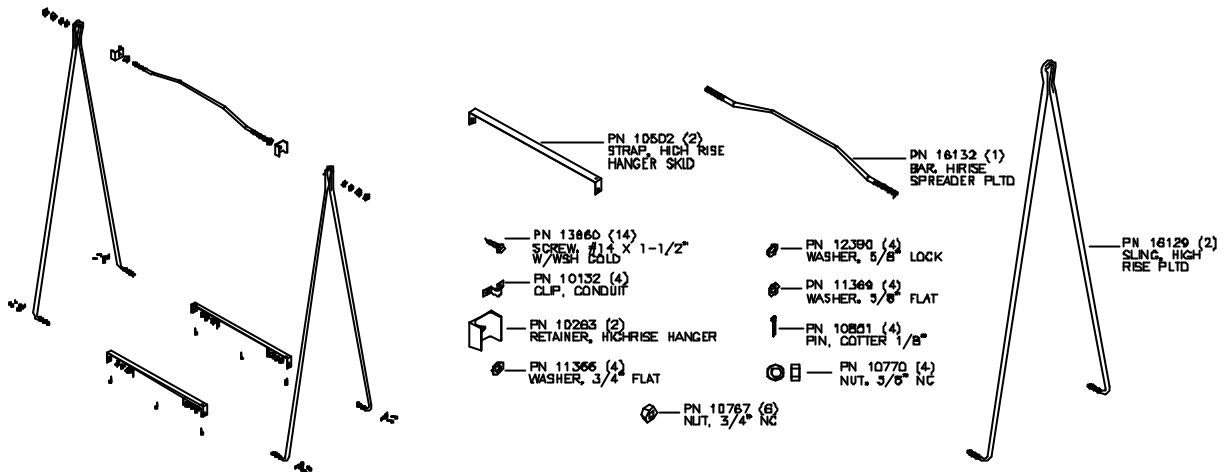

## TOOLS

- Drill ELEC/CORDLESS
- 3/4" (19mm) drill bit
- 3/8" socket driver
- Adjustable (Crescent wrench)
- Pliers

## HIGH RISE ASSEMBLY PROCEDURE

1. Tip the unit over so that the door is facing upward.
2. Insert a skid strap between the 4x4's and up against the 2x4. (See Figure A)
3. Fasten the skid strap to the 2x4 using three #14 x 1½ inch hex head screws.
4. To secure the other skid strap, repeat steps 2 and 3.
5. Drill a 3/4 inch hole through the 4x4 using the hole in the skid strap as a guide. Repeat procedure to drill the remaining three holes. (See Figure B)
6. Insert the legs of one sling into the holes in the 4x4.
7. Repeat step 6 for the opposite side sling.
8. Place the clip over the sling just above where it goes through the 4x4. (See Figure C)
9. Fasten down the clip with two #14 x 1½ inch hex head screws.

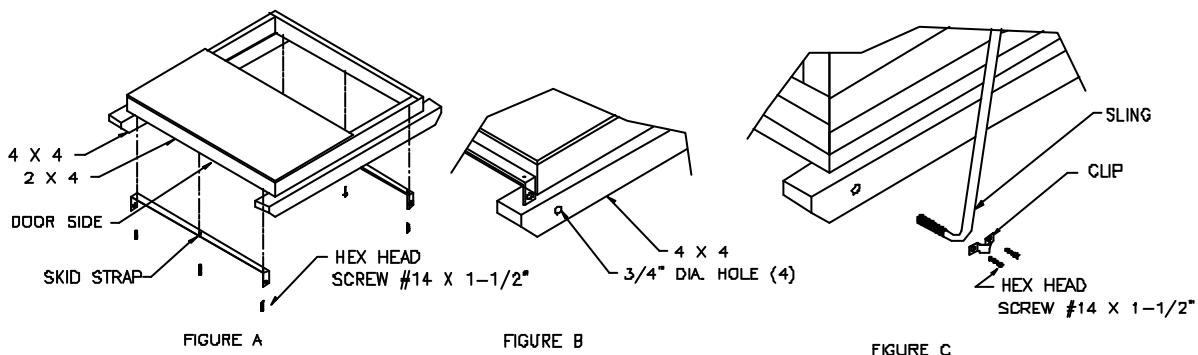

10. Repeat steps 8 and 9 for the remaining three sling legs.

11. Slip 5/8" flat washer and 5/8" lock washer on to the end of the sling up close to the skid strap. Insert 5/8" nut and tighten. (See Figure D)
12. Insert a 2-3/16" cotter pin through the hole in the end of the sling. Bend pin ends to secure.
13. For the other sling ends, repeat steps 11 and 12.
14. Set unit upright.
15. Put a 3/4" nut on each end of the spreader bar and turn until they are to the end of the threads.
16. Insert the spreader bar through the hole in retainer. Keep the flanged edge away from the nut. (See Figure F)
17. Insert the spreader bar through the sling at the narrowest point. The sling will fit into the retainer. (See Figure E)
18. Put on two 3/4" washers, then a 3/4" nut on spreader bar and tighten. (See Figure F)  
NOTE: The spreader bar should be just touching against the roof when the nuts are tightened.

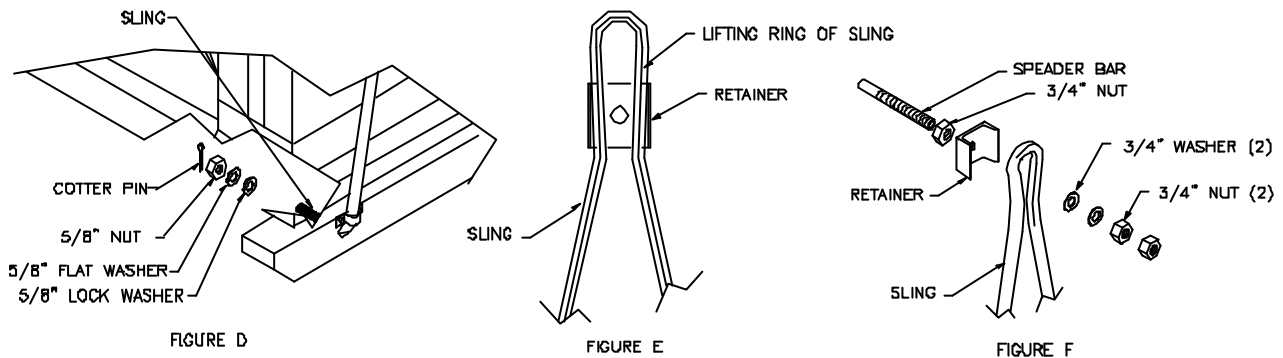

19. Put on the other 3/4" nut on the spreader bar and tighten.
20. For the opposite end of the spreader bar, repeat steps 16, 17, 18 and 19.

NOTE: When lifting by crane or etc., lift only by the ring end of each sling.



**Satellite Industries Europe:** 67 avenue de la Toison d'Or - 1060 Bruxelles - Belgium  
 tel : 0032 / 2-542 56 56 fax : 0032 / 2-542 56 57  
 moreinfo@satellite.be - www.satellite.be